

# Accessories Brochure

For Contact Lens  
Manufacturing & Handling

**Contamac**<sup>™</sup>



## Contents

Manufacturing	03
Laboratory Lens Handling	08
Packaging	09
Patient Lens Handling	13
Technical Information	15

## How to read this brochure

Recommended for:



Optimum  
F2



GM Advance  
Contaflex  
Contaflex GM3



Definitive  
Unisil

[MOQ] - Minimum Order Quantity

# Manufacturing



## High Melt Black Wax

High melt wax for blocking Hydrophilic materials. Melting point 66°C.

Colour: Black

Quantity: 1 Tub (125 g) / 10 Sticks (20 g each) <sup>(MOQ)</sup>

Code: 4110047 (Tub)  
4110048 (Sticks)



## Low Melt Black Wax

Low melt wax for blocking RGP materials. Melting point 44-51°C.

Colour: Black

Quantity: 1 Tub (125 g) / 10 Sticks (20 g each) <sup>(MOQ)</sup>

Code: 4110049 (Tub)  
4110050 (Sticks)



## Blocking Kemdent Sticky Wax

High melt wax for blocking Hydrophilic materials. Melting point 55°C.

Colour: Yellow

Quantity: 1 Box (500 g In sticks) <sup>(MOQ)</sup>

Code: 4110053



To request the Accessories  
Price List, please contact:  
sales@contamac.co.uk  
+44 (0) 1799 514800

# Manufacturing



## Contapol 1 Polish

High quality polishing compound suitable for hydrophilic materials, particularly those based on HEMA. It contains a uniformly dispersed alumina abrasive, suspended in an oil base, to produce excellent surfaces.

Quantity: 1 Pot (250 g) <sup>(MOQ)</sup>

Code: 4230001



## Contapol 2 Polish

Polish specially formulated for use in high water content materials. It contains a finely graded abrasive suspended in a fine oil base, imparting excellent surface finishes.

Quantity: 1 Pot (250 g) <sup>(MOQ)</sup>

Code: 4230002



## Contapol 3 Polish

Aqueous based premium polishing compound. Contains finely graded abrasive. Contapol 3 has a unique formula that eliminates solvent attack and enhances the wettability of the polished surface. Suitable for all RGP materials. Particularly suited to low wetting angle materials.

Quantity: 1 Bottle (1 kg) <sup>(MOQ)</sup>

1 Bottle (5 kg)

Code: 4230004 (1 kg)

4230005 (5 kg)



To request the Accessories  
Price List, please contact:  
sales@contamac.co.uk  
+44 (0) 1799 514800

**Contamac**

# Manufacturing



## Polishing Powder

Finely graded polishing powder for customers who wish to produce their own polishing compounds.

Quantity: 1 Tub (500 g) <sup>(MOQ)</sup>/1 Drum\* (10 kg)

Code: 4230006 (Tub)  
4230007 (Drum)

\*Available on request



## Delrin Polishing Cup

High quality plastic polishing cup designed for use with our Delrin Polishing Sponge for front surface polishing.

Colour: White

Quantity: 10 Units <sup>(MOQ)</sup>

Code: 4110015



To request the Accessories  
Price List, please contact:  
sales@contamac.co.uk  
+44 (0) 1799 514800

**Contamac**

# Manufacturing



## Delrin Polishing Sponge

High quality foam sponge pads designed for use with our Delrin Polishing Cup.

Quantity: 100 Units <sup>(MOQ)</sup>  
 Size: Ø 25mm x Depth 15mm  
 Code: 4110034



## Delrin Drum Polishing Sponge

High quality foam sponge pad designed for use in a Delrin drum polishing tool for the modification or finishing of rigid contact lenses and prosthetic lenses.

Quantity: 100 Units <sup>(MOQ)</sup>  
 Size: Ø 7cm x Depth 7mm  
 Code: 4110019



## Grey Roller Sponges

Designed for use with a variety of edge polishing machines.

Colour: Grey  
 Quantity: 20 Units <sup>(MOQ)</sup>  
 Size: Ø 5.5cm x Depth 4.5cm  
 (Inner circle 1cm)  
 Code: 4110058



To request the Accessories  
 Price List, please contact:  
[sales@contamac.co.uk](mailto:sales@contamac.co.uk)  
 +44 (0) 1799 514800

# Manufacturing



## Microfibre Polishing Cloth

The unique construction of the micro thin fibres is particularly suited to gas permeable lens polishing. Can be used on conventional and bladder polishing systems.

Colour: Beige  
Quantity: 1 Unit (61cm<sup>2</sup>) <sup>(MOQ)</sup>  
Code: 4110005



## Brushed Cotton Polishing Cloth

Universal polishing cloth, widely used throughout the industry, combines excellent results with low cost.

Colour: White  
Quantity: 1 Unit (1m<sup>2</sup>) <sup>(MOQ)</sup>  
Code: 4110006



To request the Accessories  
Price List, please contact:  
sales@contamac.co.uk  
+44 (0) 1799 514800

# Laboratory Lens Handling



## Tweezers

Large lens tweezers with replaceable super soft silicone tips for increased protection when handling soft or silicone hydrogel contact lenses.

Colour: White

Quantity: 250 Units <sup>(MOQ)</sup>

Code: 4110059



## Tweezer Tips

Replacement super soft silicone tips for white tweezers.

Quantity: 1000 Units <sup>(MOQ)</sup>

Code: 4110043



## Laboratory Lens Handler

High quality two part green polishing suction holder designed for handling gas permeable lenses during edge polishing. Two profiles included to allow a variety of RGP designs to be held.

Colour: Green

Quantity: 2 Units <sup>(MOQ)</sup>

Size: Convex 8mm, Concave 9.5mm

Code: 4110039



To request the Accessories  
Price List, please contact:  
sales@contamac.co.uk  
+44 (0) 1799 514800



# Packaging

## Glass Vial

Glass vial manufactured from type 1 neutral glass and fully autoclavable. Compatible with Tear Off Aluminium Seal and Siloprene Bungs. Available in two tray sizes.

Quantity: 186 Units/208 Units <sup>(MOQ)</sup>

Size: 5ml, 20mm

Code: 4110044 (186 Units)  
4110045 (208 Units)



For technical info (186) [click here](#)

For technical info (208) [click here](#)

## Siloprene Bung

Made from the finest pure siloprene, these stoppers are fully autoclavable and designed for use with our Glass Vials and both types of Crimp Top Seals. Packed without silicone lubricating oil.

Quantity: 1500 Units <sup>(MOQ)</sup>

Size: Ø 20mm

Code: 4110004



For technical info [click here](#)

To request the Accessories  
Price List, please contact:  
[sales@contamac.co.uk](mailto:sales@contamac.co.uk)  
+44 (0) 1799 514800

# Packaging

## Tear Off Aluminium Seal



All aluminium seal with tear out tab that allows the complete removal of the closure prior to or after use. For use with Steel Hand Crimper Gun, Glass Vial and Siloprene Bung.

Colour: Blue, Gold, Green, Red, Silver

Quantity: 1000 Units <sup>(MOQ)</sup>

Size: 20mm

Code: Blue - 4110008      Red - 4110013  
 Gold - 4110011      Silver - 4110014  
 Green - 4110012



For technical info [click here](#)

## Flip Tear Up Seal



Seal with plastic button attached to help facilitate the activation and complete removal of the seal from the container. For use with Steel Flip Off Hand Crimper Gun, Glass Vial and Siloprene Bung.

Colour: White, Blue

Quantity: 1000 Units <sup>(MOQ)</sup>

Size: 20mm

Code: Blue - 4110009  
 White - 4110010



For technical info [click here](#)

To request the Accessories Price List, please contact:  
 sales@contamac.co.uk  
 +44 (0) 1799 514800

# Packaging



## Steel Hand Crimper Gun

Hand Crimper for manual crimping of Tear Off Aluminium Seals to Glass Vials.

Quantity: 1 Unit <sup>(MOQ)</sup>

Size: 20mm

Code: 4110031



## Steel Flip Off Hand Crimper Gun

Hand Crimper for manual crimping of Aluminium Flip Tear Up Seals to Glass Vials.

Quantity: 1 Unit <sup>(MOQ)</sup>

Size: 20mm

Code: 4110018



To request the Accessories  
Price List, please contact:  
[sales@contamac.co.uk](mailto:sales@contamac.co.uk)  
+44 (0) 1799 514800

**Contamac**

# Packaging



## Double Soft Lens Mailers

High quality double mailer in clear plastic, affording excellent protection for soft lenses. This mailer can also be used for larger RGP lenses up to approximately 16mm in diameter.

Quantity: 100 Units <sup>(MOQ)</sup>

Code: 4110027

FDA Approved



For technical info [click here](#)

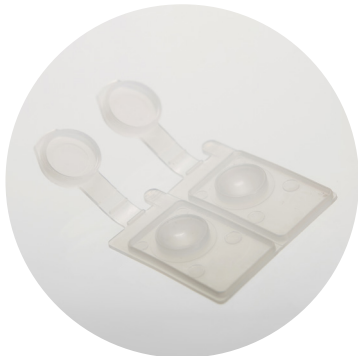

## Double GP Mailers

High quality double mailers are available in clear plastic and designed for use with RGP lenses. Can be cut for use as single units.

Quantity: 250 Units <sup>(MOQ)</sup>

Code: 4110026

FDA Approved



For technical info [click here](#)

To request the Accessories  
Price List, please contact:  
sales@contamac.co.uk  
+44 (0) 1799 514800

**Contamac**

# Patient Lens Handling



## DMV RGP Lens Remover Ultra

High quality solid rubber lens remover designed for RGP lenses.  
Supplied in individual storage cases.

Colour: Orange

Quantity: 3 Units <sup>(MOQ)</sup>

Code: 4110041



Item cannot be supplied to EU



## DMV Soft Lens Handler/Remover

A durable rubber removal device specifically designed for soft and silicone hydrogel lenses. Ideal for patients with limited handling ability or for those who have difficulty touching their eyes. Supplied in individual storage cases.

Quantity: 3 Units <sup>(MOQ)</sup>

Code: 4110033



Item cannot be supplied to EU

To request the Accessories  
Price List, please contact:  
sales@contamac.co.uk  
+44 (0) 1799 514800

# Patient Lens Handling



## DMV Scleral Suction Holder

Lens inserter and remover made from high purity rubber. Designed specifically for use with scleral and other large diameter lenses.

Colour: Blue

Quantity: 3 Units <sup>(MOQ)</sup>

Code: 4110040



Item cannot be supplied to EU



## RGP Lens Inserter/Remover

A lower cost alternative RGP lens inserter and remover, hollow for increased suction. Supplied in individual storage cases.

Colour: Green

Quantity: 10 units <sup>(MOQ)</sup>

Code: 4110037



Item cannot be supplied to EU

To request the Accessories  
Price List, please contact:  
sales@contamac.co.uk  
+44 (0) 1799 514800

**Contamac**

# Technical Information

## Glass Vial (186) 5ml

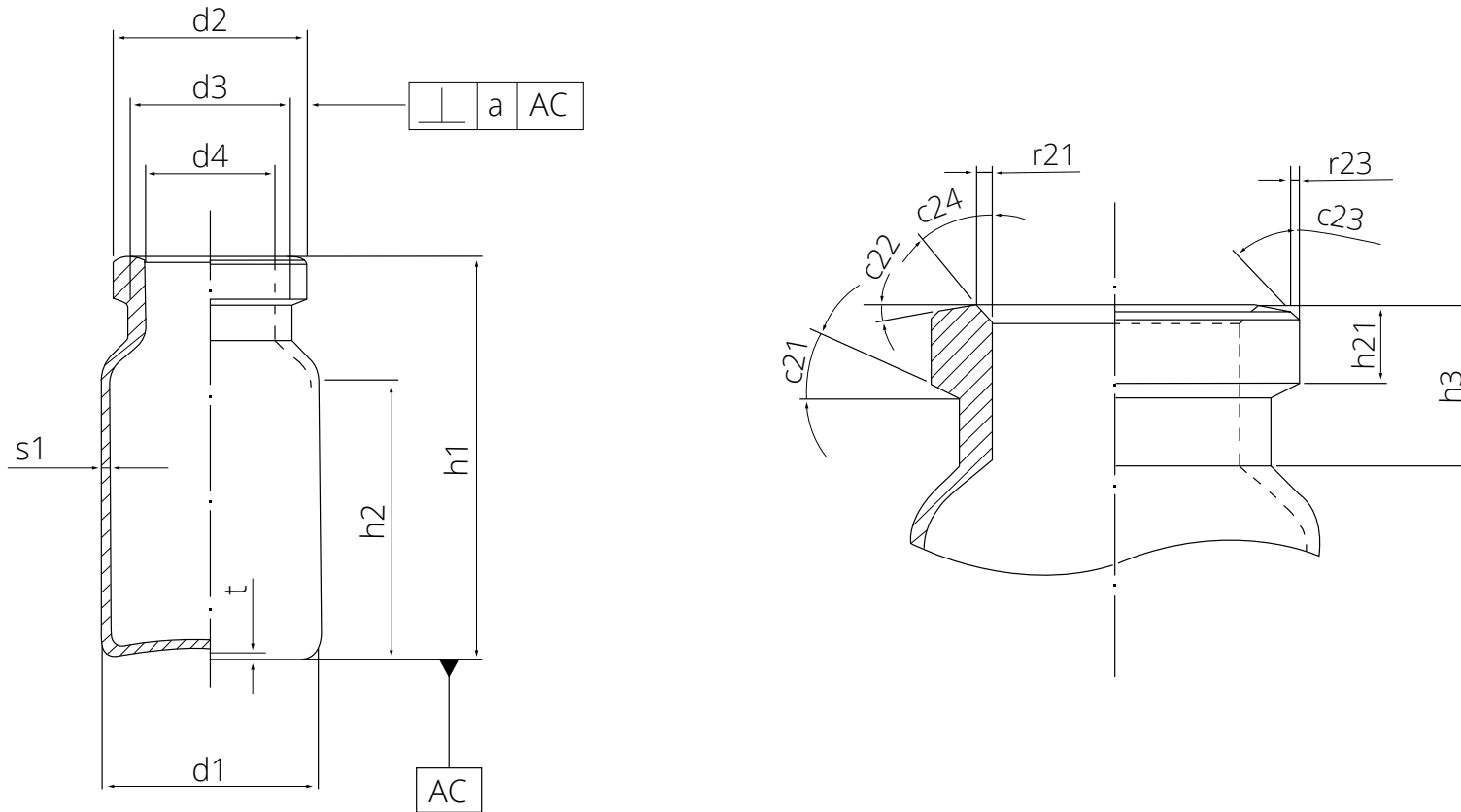

d1	22,25	+0,25	-0,25	h3	7,75	+0,5	-0,5	s1	1,1	+0,05	-0,05
d2	19,9	+0,2	-0,2	h21	3,0	+0,2	-0,2	r21	0,5	+0,2	-0,2
d3	16,05	max.		c21*	30,0	+5,0	-5,0	r23	0,5	ca.	
d4	12,75	+0,15	-0,15	c22*	5,0	+2,0	-2,0	t	0,4	+0,3	-0,3
h1	38,0	+0,5	-0,5	c23*	45,0	ca.		a	0,66		
h2	24,5	min.		c24*	45,0	ca.					

To request the Accessories  
Price List, please contact:  
sales@contamac.co.uk  
+44 (0) 1799 514800

# Technical Information

## Glass Vial (208) 5ml

## Siloprene Bung 20mm

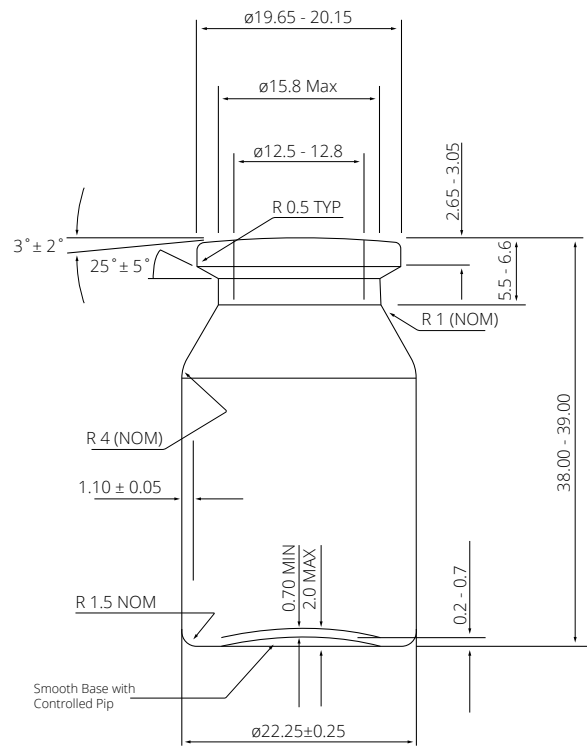

MATERIAL: Type 1, Clear Neutral Glass

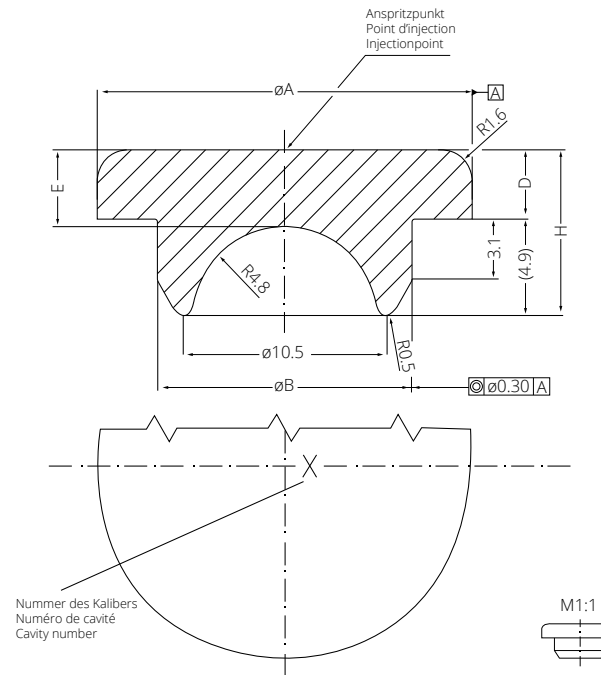

Richtmasse Dimensions Indicatives Standard Dimnsions	19.3	13.1	3.5	3.9	8.4
$\varnothing A \pm 0.1$	$\varnothing B \pm 0.1$	$D \pm 0.3$	$E \pm 0.1$	$H \pm 0.4$	



# Technical Information

## Tear Off Aluminium Seal

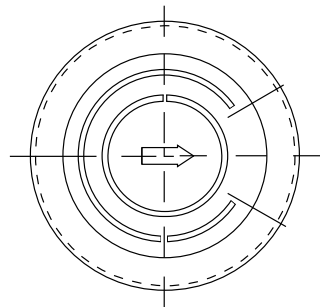
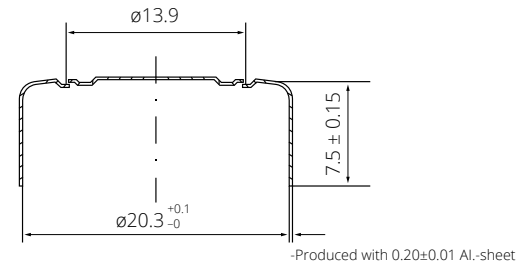

M1:1



## Flip Tear Up Seal

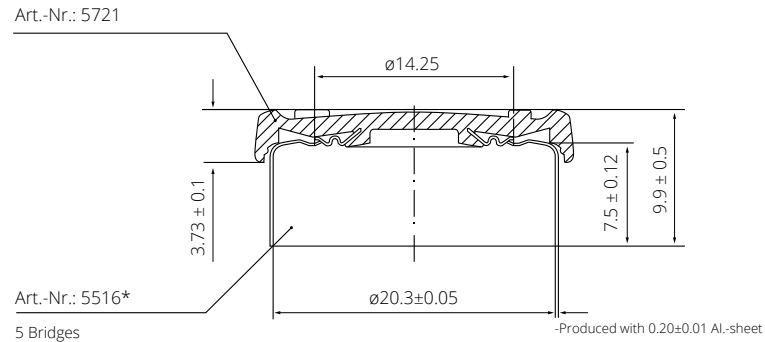

\*Cavity marking is possibly visible when looking on the inner aluminium shell surface

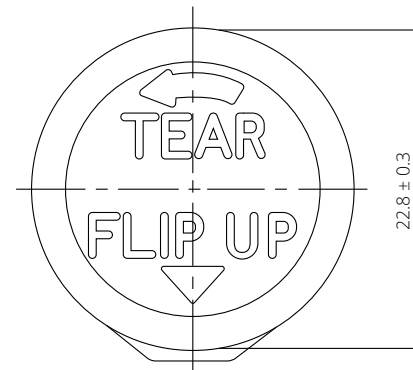

M1:1

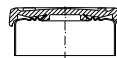

# Technical Information

## Double GP Mailer

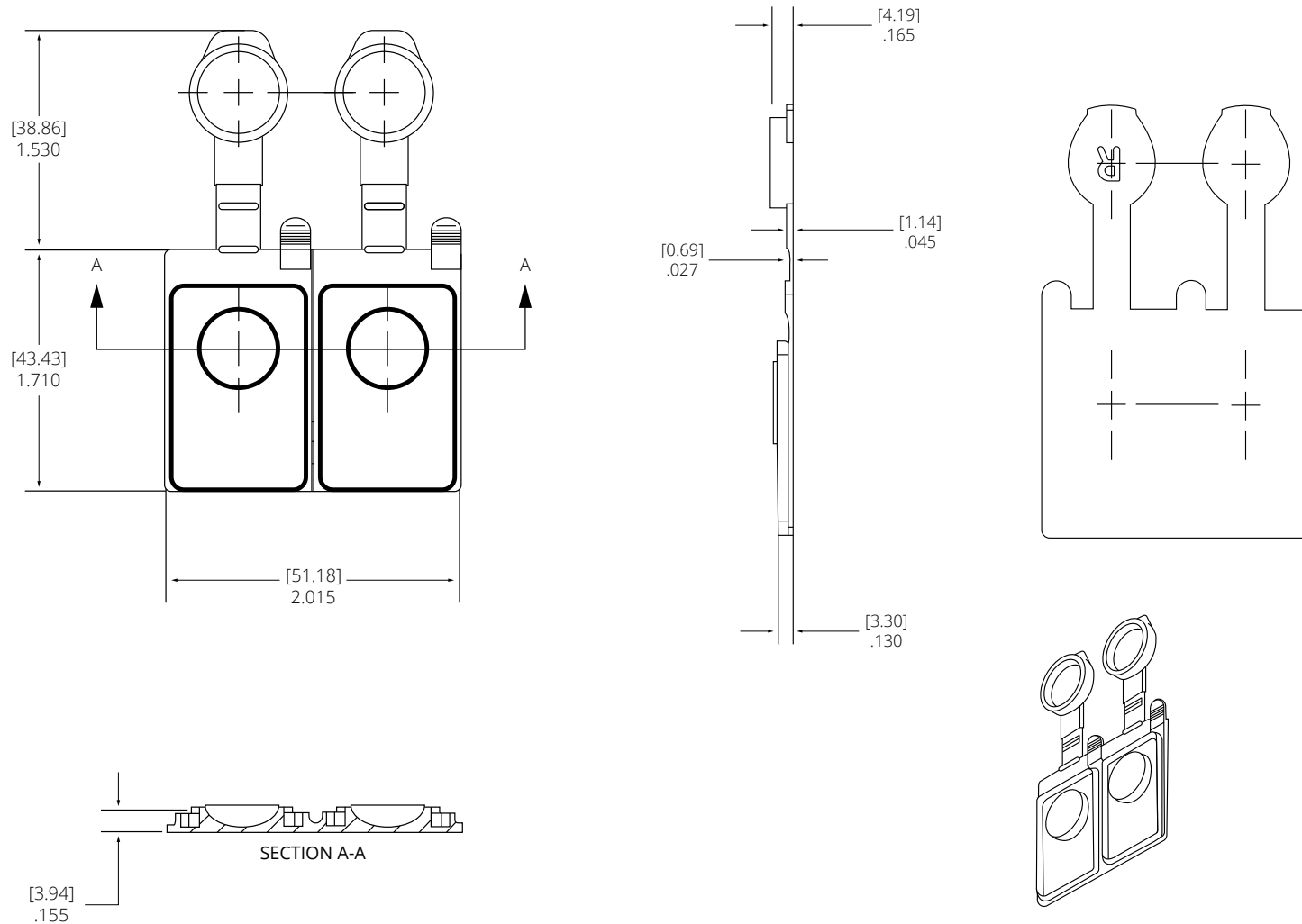

[Product Info](#)

To request the Accessories  
Price List, please contact:  
sales@contamac.co.uk  
+44 (0) 1799 514800

**Contamac**

# Technical Information

## Double Soft Lens Mailers

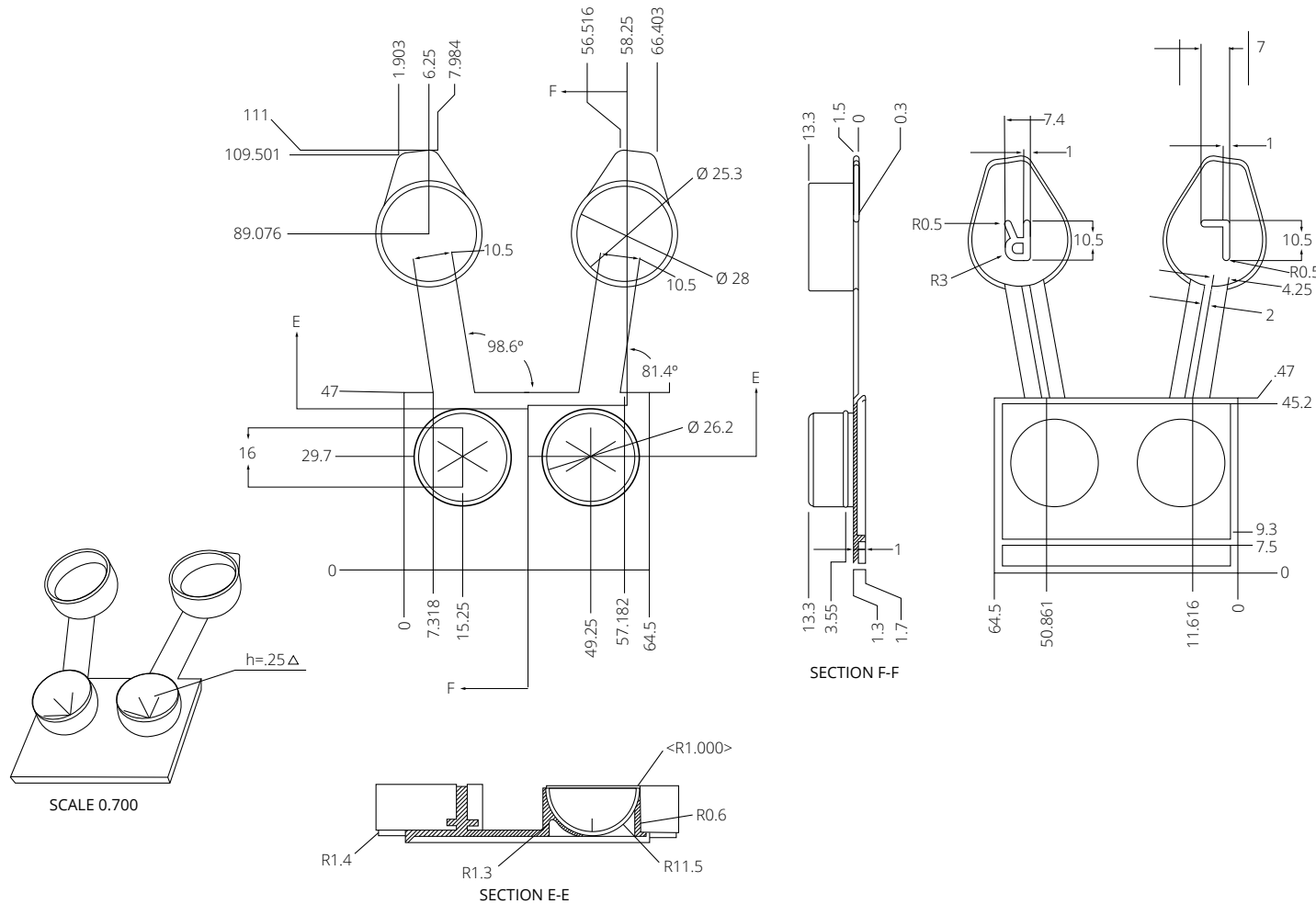

To request the Accessories Price List, please contact:  
[sales@contamac.co.uk](mailto:sales@contamac.co.uk)  
 +44 (0) 1799 514800

To request the Accessories  
Price List, please contact:  
[sales@contamac.co.uk](mailto:sales@contamac.co.uk)  
+44 (0) 1799 514800

**Contamac**<sup>™</sup>

